



8111757

EXP'AIR automatic Aluminium



PRODUCT ADVANTAGES

- 35% more economical than competitors' models
- 50% quieter than competitors' models
- 100% accessible by people with reduced mobility and small children

Exp'air automatic Aluminium hand dryer with forced air. Anti-vandalism with aluminum hood and adapted to people with reduced mobility. Equipped with a water recovery tank or a direct evacuation solution. 3 years warranty.

**10 YEARS
REPAIRABLE**



**MADE IN
FRANCE**



JVD Spain
jvd.es

-

JVD France
jvd.fr

-

JVD Singapore
jvd.sg

-

JVD Mexico
jvd.mx

8111757



EXP'AIR automatic **Aluminium**

SPECIFICATIONS

Material	Aluminum
Colour	Chrome
Water tray	Yes
Water tray capacity (mL)	0.6000
Drain connection	Optional
Drying time (s)	10-15s
Sound level (dB) (1m in front of the appliance)	75
Outlet air speed (m/s)	600
Air flow rate (m³/h)	140
Air outlet temperature (°C)	40
Safety in case of malfunction	Yes
Filter	Copper filter
Vandal-safe	Yes
Antibacterial treatment	Yes
Drying zone lighting	Yes

ELECTRICAL

Rated Power (W)	800
Voltage	220-240V
Frequency (Hz)	50
Standby power consumption (W)	30.0000
Detection type	Capacitive
Motor speed (rpm)	26500
Type of motor	Brushed AC
Motor lifetime (number of operations)	350000

DIMENSIONS

Height (mm)	430
Width (mm)	340
Depth (mm)	234
Weight (kg)	6.9400

BOX DIMENSIONS

Height (mm)	240
Width (mm)	360
Depth (mm)	490
Weight (kg)	8.0100

TECHNICAL DRAWING

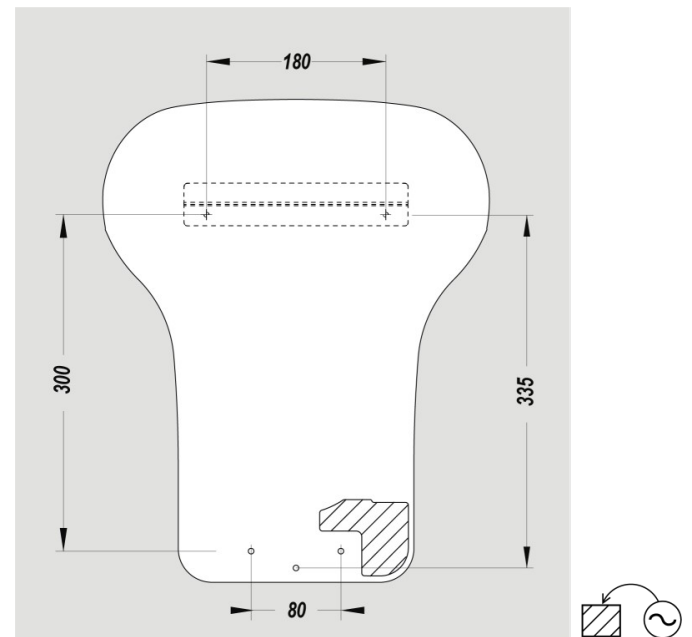
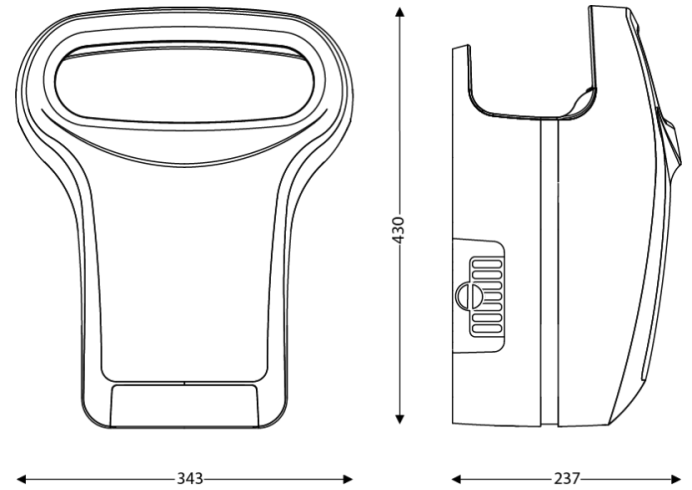

RECOMMENDED INSTALLATION HEIGHTS

- Men installation height (cm) : 75
- Women installation height (cm) : 65
- Children installation height (cm) : 55
- Disabled person installation height (cm) : 65

